

# BAKMIX

AUTOMATIC CONTINUOUS DOUBLE SCREW DOUGH MIXER



rev. 006.2405.75

## ■ Bakmix

- Dual-screw continuous dough kneading machine for sheet pasta, regional pasta, pizza, bread and gnocchi
- Variable dough kneading system thanks to two dough mixing screws
- Production output: 100 - 2,000 kg/h
- Correct hydration irrespective of particle size along with precise and repeatable dosing
- PLC controlled recipe management

Automatic continuous stainless steel made complete of dry and liquid ingredients dosing device systems. It allows you to produce a continuous consistent dough with minimal operator intervention. Specifically designed for: bakery (pizza, bread, breadstick, dry toast, ecc.), fresh and dry pasta, gnocchi.

## Main technical features:

- Raw material premixer system Premix<sup>®</sup> complete of volumetric dosing device for flours and electronic dosing device for liquid ingredients
- Stainless steel double screws system to obtain the best uniformity of the dough
- Touch screen panel PLC to guarantee the complete management of dosing and recipes

## Advantages:

- Elimination of standard mixing batch systems
- Small Foot Print
- Constant dough quality over time
- Large capacity production range
- Low energy consumption.
- Suitable for many layout for automatic lines

## Optional:

- Gravimetric dosing device for flour and special dry ingredients
- Fixed or portable mounted trolley models
- Customized double screw system layout for a wide range of dough



Gnocchi



Pizza



Fresh pasta



Filled pasta

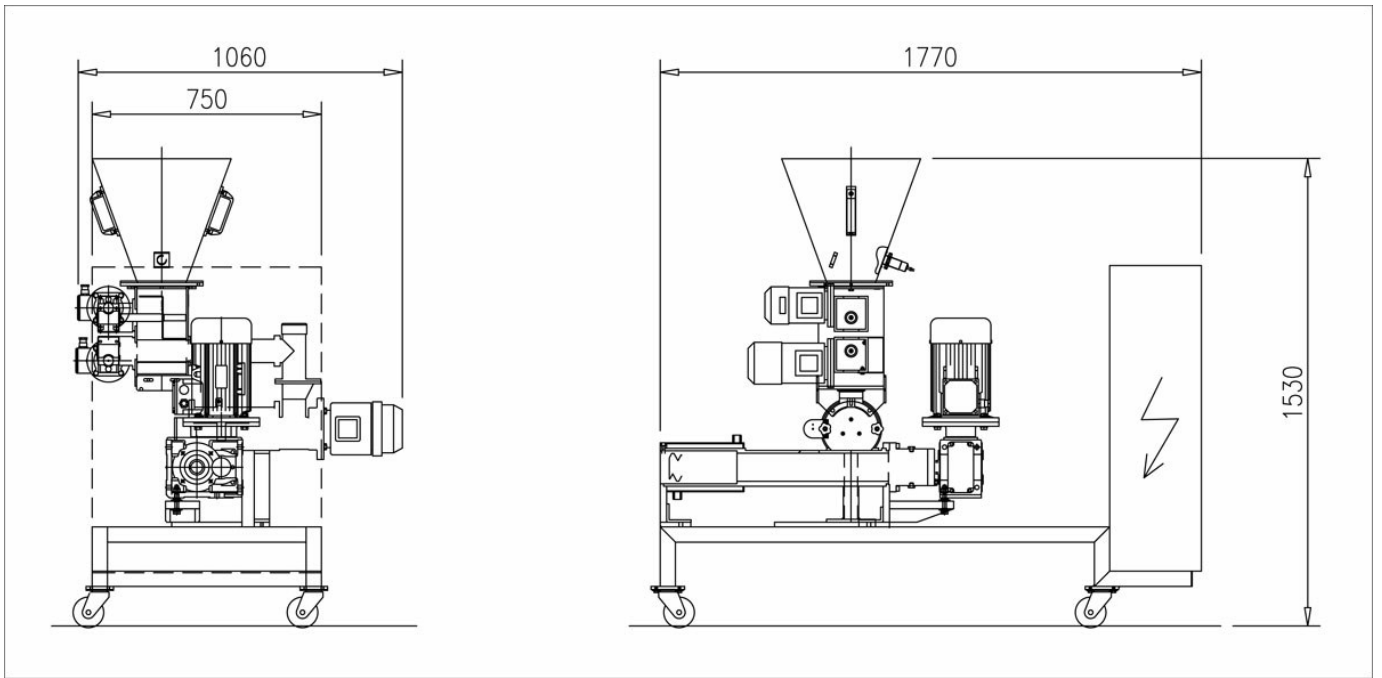



[facebook.com/storci.spa](https://facebook.com/storci.spa)



[youtube.com/user/StorciPastaMachinery](https://youtube.com/user/StorciPastaMachinery)



[linkedin.com/company/storci-spa](https://linkedin.com/company/storci-spa)

**Storci S.p.A.**  
via Lemignano, 6 - 43044 Collecchio (Parma)  
phone: +39 0521 543611 fax: +39 0521 543621  
[www.storci.com](http://www.storci.com) - [sales-storci@storci.com](mailto:sales-storci@storci.com)

