

Storci

PASTA MACHINERY

STE 1120-1500 FB SPREADING MACHINE

AUTOMATIC SPREADING MACHINES FOR LONG-CUT
PASTA



rev. 0044.2405.30

■ Spreading machine, mod. STE 1500 FB

- Automatic spreading machines for long-cut pasta with 1120 and 1500 mm sticks
- Standard pasta types (*spaghetti*, *tagliatelle*, etc.) and special types [*candele*, *ziti*, *fusilli bucati* (hollow fusilli) etc.]
- Automatic system for collecting and grinding pasta scraps
- Automatic stick pick-up and regulation of the pasta cutting length

we know pasta

STE 1120-1500 FB SPREADING MACHINE

Spreading machines suitable for long-cut pasta lines to be coupled to linear heads, specifically for standard and special pasta types and *fusilli bucati lunghi* (long hollow fusilli). PLC control. The new design, the use of new materials, the technical solutions adopted and the particularly sturdy framework have made it possible to construct easy-to-clean and low-maintenance machine.

Main technical features:

- Empty stick accumulation guides with manual feed
- Automatic pick-up of the sticks by means of chains with loops
- Upper ventilation ring for surface drying the pasta
- Arms with chains for automatic feeding of the long-cut pasta pre-drying tunnel
- Pneumatic conveyor system for taking pasta scraps to the press kneader, complete with fan-grinder, stainless steel transport piping, decantation cyclone and vacuum seal valve
- Painted steel structure
- Wheeled unit to facilitate press cleaning
- Differentiated cutting: short (290 mm) and long (580 mm)

Plus:

- Guillotine cutter for top cutting the long pasta arriving from the linear head of the press
- First guillotine cutter for trimming the product
- Stick lift with fins for positioning the sheets of long pasta in the second guillotine-type trimmer
- Second guillotine cutter for final trimming of long-cut pasta and *fusilli*; final trimming length = 195 - 645
- Internal conveyor for collecting pasta scraps made by the trimmer
- External transversal conveyor with two-way travel for taking scraps to the grinder



Application of STE 1500 FB on long-cut pasta line
130.1-1500/1 TV



Application of STE 1120 FB on long-cut pasta line
130.1-1120/1 TV



Application of spreading machine STE 1500 FB on long-cut pasta line
130.1-1500/1 TV



Spreading machine, mod. STE 1500 FB

STE 1120-1500 FB SPREADING MACHINE

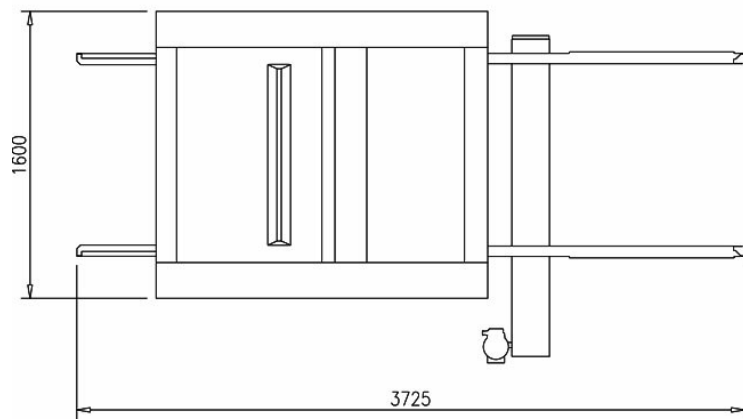
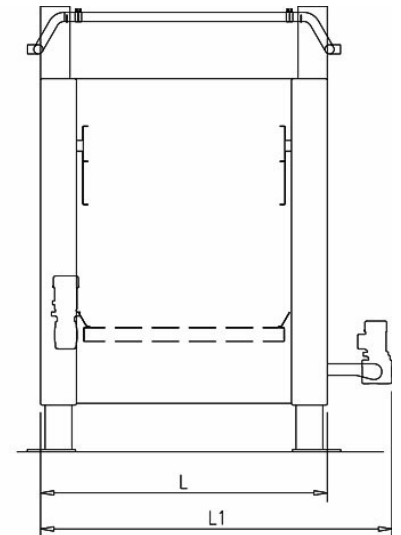
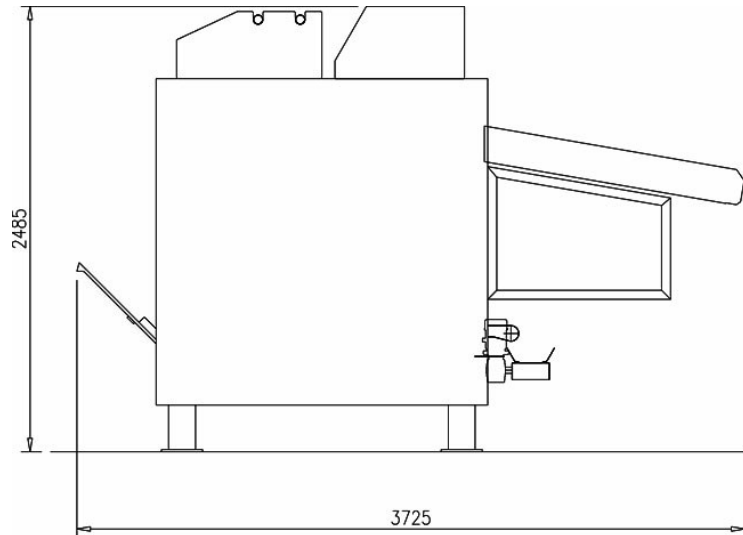

STE 1120-1500 FB		
	STE 1120 FB	STE 1500 FB
Nominal stick length (mm)	1120	1500
Dry Production (kg/h) for standard pasta types	400	500
Dry Production (kg/h) for <i>candele</i>	180	240
Dry Production (kg/h) for <i>fusilli bucati</i>	120	160
Tray passage system	no	no
Cutting length (mm)	290 and 580	290 e 580
Power installed	11	11
Size	1960x3725x2485	2340x3725x2485

STE 1120-1500 FB		
PASTA TYPES	STE 1120 FB	STE 1500 FB
Standard long-cut (e.g. spaghetti) Ø max. 1.7 mm	•	•
Bucati (Tubular pasta) (e.g. bucatini) Ø max. 3.5 mm	•	•
Tagliatelle: max. width 6 mm	•	•
Bucati speciali (special tubular pasta) (candele, ziti, etc.)	•	•
American lasagna	•	•
Fusilli bucati lunghi (long hollow fusilli)	•	•

Notes: the data provided is purely indicative and not binding as it may be subject to the variability of products and the line in which units are installed.



facebook.com/storci.spa



youtube.com/user/StorciPastaMachinery



linkedin.com/company/storci-spa

Storci S.p.A.
via Lemignano, 6 - 43044 Collecchio (Parma)
phone: +39 0521 543611 fax: +39 0521 543621
www.storci.com - sales-storci@storci.com

